



# **FITTING INSTRUCTIONS**

Part Number: **5414200**  
Product **UNDER VEHICLE PROTECTION**  
Description:  
Suited to **TOYOTA HILUX & FORTUNA 2015 ON**  
vehicle/s:

## **WARNING**

### **REGARDING VEHICLES EQUIPPED WITH SRS AIRBAG:**

When installed in accordance with these instructions, the vehicle protection panels do not affect operation of the SRS airbag.

### **ALSO, NOTE THE FOLLOWING:**

- ◆ This product must be installed exactly as per these instructions using only the hardware supplied.
- ◆ Do not use this product for any vehicle make or model, other than those specified by ARB.
- ◆ Do not remove labels (if any) from this product.
- ◆ This product or its fixing must not be modified in any way.
- ◆ The installation of this product may require the use of specialized tools and/or techniques
- ◆ These instructions are correct as at the publication date. ARB Corporation Ltd. cannot be held responsible for the impact of any changes subsequently made by the vehicle manufacturer
- ◆ During installation, it is the duty of the installer to check correct operation/clearances of all components
- ◆ Work safely at all times
- ◆ Unless otherwise instructed, tighten fasteners to specified torque

## **ARB 4x4 ACCESSORIES**

### **Corporate Head Office**

42-44 Garden St  
Kilsyth, Victoria  
AUSTRALIA 3137

Tel: +61 (3) 9761 6622  
Fax: +61 (3) 9761 6807

Australian enquiries  
North & South American enquiries  
Other international enquiries

sales@arb.com.au  
sales@arb.com.au  
exports@arb.com.au

**[www.arb.com.au](http://www.arb.com.au)**

# IMPORTANT INFORMATION. GENERAL CARE AND MAINTENANCE

By choosing ARB vehicle protection, you have bought a product that is one of the most sought after 4WD products in the world. Your under vehicle protection panels are a properly engineered, reliable, quality accessory that represents excellent value.



- While these panels have been engineered for strength and functionality care and good judgment should be taken when traversing difficult off-road conditions to minimise damage to panels and vehicle.
- During servicing when panels are removed ensure fasteners are re-fitted to the correct torque values.
- Inspect panels visually on a regular basis. Dirt and foreign matter should be washed out to minimise build-up around hot components. **BE VERY CAREFUL** when removing foreign matter with hands while vehicle is hot or running. Replace any components as necessary. This service can be performed by your local authorized ARB Stockist.

## FITTING REQUIREMENTS

### REQUIRED TOOLS FOR FITMENT OF PRODUCT:

<b>BASIC TOOL KIT</b>	<b>TORQUE WRENCH (22Nm – 44Nm)</b>
-----------------------	------------------------------------

### HAVE AVAILABLE THESE SAFETY ITEMS WHEN FITTING PRODUCT:

<b>Protective eyewear</b>	<b>Hearing protection</b>
	

**NOTE: 'WARNING' notes in the fitting procedure relate to OHS situations, where to avoid a potentially hazardous situation it is suggested that protective safety gear be worn or a safe work procedure be employed. If these notes and warnings are not heeded, injury may result.**

### FASTENER TORQUE SETTINGS:

SIZE	Torque Nm	Torque lbft
M6	9Nm	7lbft
M8	22Nm	16lbft
M10	44Nm	32lbft
M12	77Nm	57lbft

## PARTS LISTING

APPLICATION.	PART NO.	QTY.	DESCRIPTION.
FIT FRONT PANEL	<b>6523081</b>	<b>1</b>	<b>FRONT UVP ASSEMBLY</b>
	6151022	4	BOLT M8 x 1.25 x 25
	4584311	4	WASHER FLAT M8x18x2
FRONT PANEL TO BULL BAR	6151022	4	BOLT M8 x 1.25 x 25
	4584311	4	WASHER FLAT M8x18x2
	6151303	4	NUT CAGED M8
FRONT PANEL TO OEM BUMPER ONLY	6151300	2	NUT CAGED M6
FIT SUMP PANEL	<b>6523083</b>	<b>1</b>	<b>SUMP UVP ASSEMBLY</b>
	6151022	7	BOLT M8 x 1.25 x 25
	4584311	7	WASHER FLAT M8x18x2
	6151132	3	NUT FLANGE M8 x 1.25 ZP
FIT TRANSMISSION PANEL	<b>6523085</b>	<b>1</b>	<b>TRANSMISSION UVP ASSEMBLY</b>
	6151022	3	BOLT M8 x 1.25 x 25
	4584311	3	WASHER FLAT M8x18x2
	6151132	3	NUT FLANGE M8 x 1.25 ZP
	6151357	2	BOLT SEMS M10 X 30 ZP Gd 8.8
	3759081	2	NUT PLATE M10
FIT TRANSFER PANEL	<b>6523065</b>	<b>1</b>	<b>TRANSFER CASE UVP</b>
	6151022	4	BOLT M8 x 1.25 x 25
	4584311	4	WASHER FLAT M8x18x2

## FITTING PROCEDURE

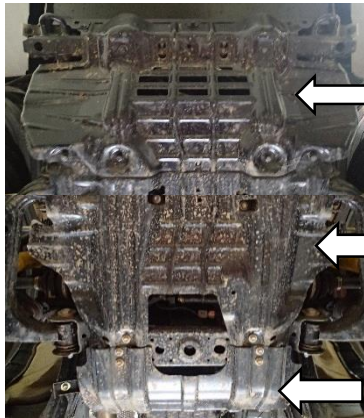

← FRONT PANEL

← SUMP PANEL

← TRANSMISSION  
PANEL



← TRANSFER  
CASE PANEL

- ALL VEHICLES:** Remove OEM panels from vehicle and retain bolts and fasteners.

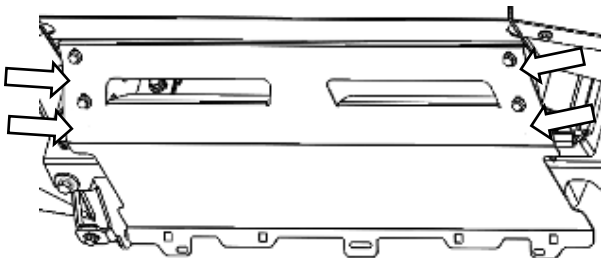

### **FOR FITMENT TO ARB BULL BAR**

- Loosen 4 X M8 bolts on STONE GUARD.

## FITTING PROCEDURE - Continued

### FITMENT TO OEM BUMPER:

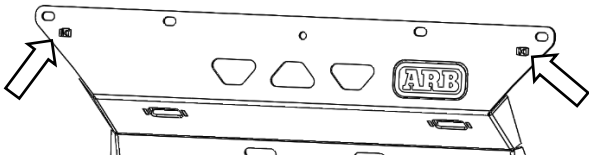

### FITMENT TO ARB BULL BAR:

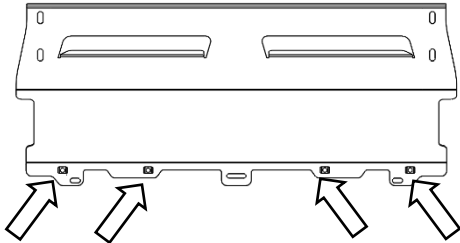

### FOR FITMENT TO OEM BUMPER

3. Insert 2x NUT CAGED M6 into FRONT PANEL as shown.

*NOTE: For fitment to OEM BUMPER FRONT PANEL; sits behind trim panel.*

### FOR FITMENT TO ARB BULL BAR

4. Insert 4x NUT CAGED M8 into centre STONE GUARD of bull bar as shown.

*NOTE: For fitment to ARB BULL BAR FRONT PANEL; sits in front of STONE GUARD.*

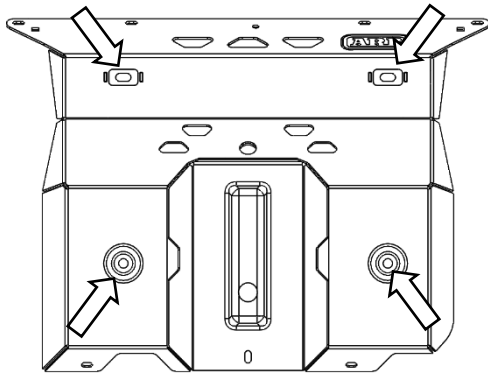

5. Secure the FRONT PANEL using 4 x M8 bolts and flat washers. **Leave finger tight.**

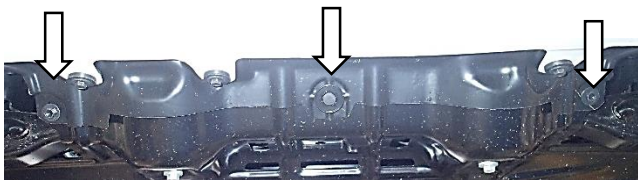

### FOR FITMENT TO OEM BUMPER

6. Secure FRONT PANEL to trim using 2 X OEM M6 fasteners and 1 X OEM clip removed in step 1. Tighten these bolts to prescribed torque

M6 fasteners;



9 Nm.



### FOR FITMENT TO ARB BULL BAR

7. Secure FRONT PANEL to STONE GUARD using 4 x M8 bolts and flat washers. Tighten these bolts and 4 X M8 bolts loosened in step 2 on STONE GUARD to prescribed torque.



M8 - 22 Nm.

## FITTING PROCEDURE - Continued

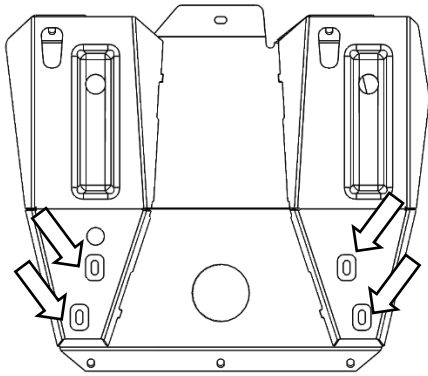

- Secure the SUMP PANEL to chassis using 4 x M8 bolts and flat washers. **Leave finger tight.**

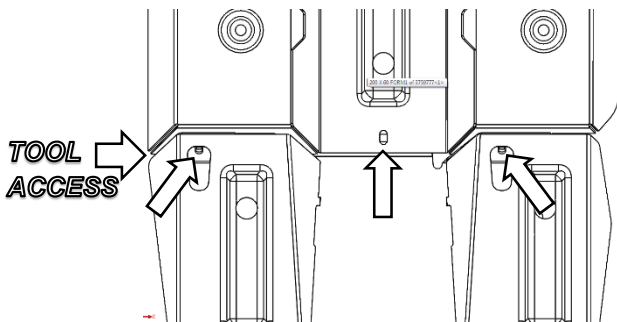

- Secure rear of FRONT PANEL to front of SUMP PANEL using 3 x M8 bolts, flat washer and flange nuts. **Leave finger tight.**

*NOTE: Tool access to LH fixing is possible from RH side of vehicle.*

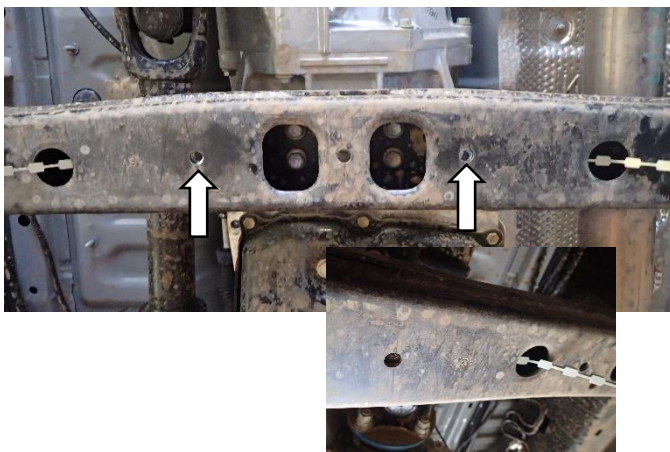

- Insert 2 x NUT PLATES into transmission cross member and align with holes as shown.

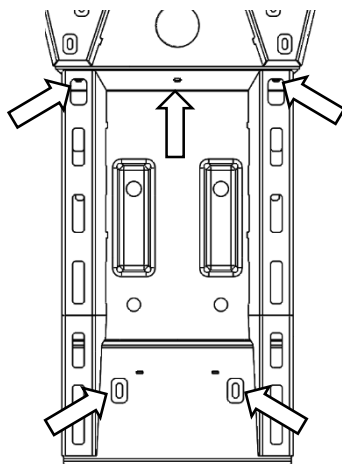

- With the help of another person or a jack lift the TRANSMISSION PANEL into place and secure rear of TRANSMISSION PANEL to nut plates using 2 x M10 SEMS bolt. **Leave finger tight.**
- Secure the front section using 3 x M8 bolts, flat washers and flange nuts. **Leave finger tight.**

## FITTING PROCEDURE - Continued

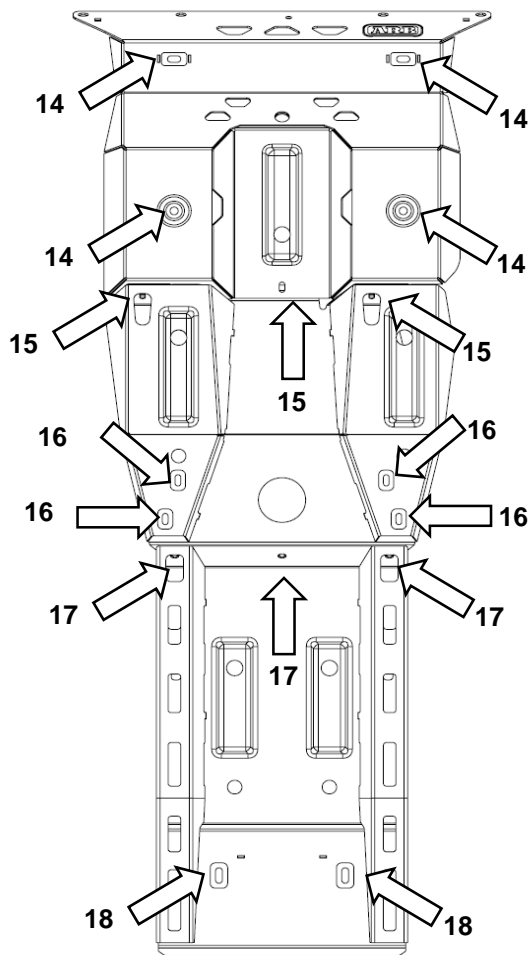

13. Tighten 4 x M8 bolts fixing FRONT PANEL to chassis to prescribed torque.

 **M8 - 22 Nm.**

14. Tighten 3 x M8 bolts securing FRONT PANEL to front of SUMP PANEL to prescribed torque.

 **M8 - 22 Nm.**

15. Tighten 4 x M8 bolts securing SUMP PANEL to chassis to prescribed torque.

 **M8 - 22 Nm.**

16. Tighten 3 x M8 bolts securing SUMP PANEL to front of TRANSMISSION PANEL to prescribed torque.

 **M8 - 22 Nm.**

17. Tighten 2 x M10 bolts securing TRANSMISSION PANEL to chassis to prescribed torque.

 **M10 - 44 Nm.**



18. Fit transfer panel as shown using 4 x M8 bolts and flat washers. Tighten to prescribed torque.

 **M8 - 22 Nm.**

19. Discard unused fasteners.

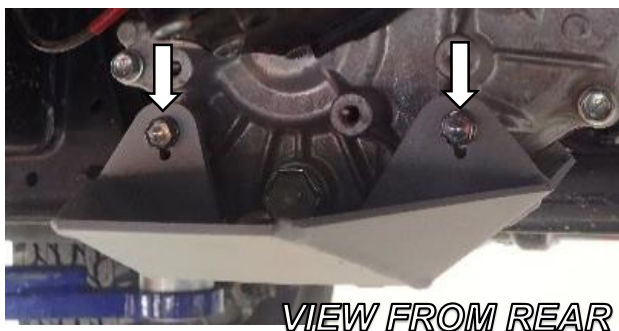

**ONCE UNDER VEHICLE PROTECTION IS FITTED:**

- Ensure all Panels are securely fastened.
- Ensure all bolts are tensioned correctly.
- Ensure panels are clear of piping.
- Ensure panels are clear of wiring.
- Ensure panels are clear of moving parts.

**Fitted Product – UVP HILUX 15 ON**

